

Alvium

G5-530 VSWIR



- IMX992 VSWIR sensor
- GigE Vision
- High bandwidths
- 3 lens mount options

Hardware option: Closed Housing C-Mount

Alvium G5 - Speed up your vision application

5GigE Vision camera for demanding applications

Alvium G5-530 VSWIR with Sony IMX992 | InGaAs runs 84.0 frames per second at 5.3 MP resolution.

The Alvium G5 camera series combines the advantages of the 5GigE interface for higher bandwidth and the flexibility of the Alvium platform offering various mount and sensor options. It enables an easy upgrade of existing systems (USB3 Vision or GigE Vision) and offers backwards compatibility with 1000BASE-T solutions. Powered by ALVIUM® Technology, the sugar cube Alvium G5 camera delivers highest image quality at a low power consumption.

Easy software integration with **Vimba X** and compatibility to the most popular third party image-processing libraries.

Specifications

Product code	21180
Interface	IEEE 802.3 5GBASE-T, 1000BASE-T, IEEE 802.3af Power Class 0 PoE
Resolution	2592 (H) × 2056 (V)
Spectral range	400 to 1700 nm
Sensor	Sony IMX992 InGaAs
Sensor type	InGaAs
Shutter mode	GS (Global shutter)
Sensor size	Type 1/1.4 VSWIR
Pixel size	3.45 μm × 3.45 μm
Lens mount	C-Mount
Max. frame rate at full resolution	84 fps at 525 MByte/s, Mono8
ADC	12 Bit
Image buffer (RAM)	512 MByte
Non-volatile memory (Flash)	1024 KByte

Output

Bit depth	8-bit, 10-bit, 12-bit; Adaptive (10-bit, 12-bit)
Monochrome pixel formats	Mono8 (default), Mono10, Mono10p, Mono12, Mono12p, Mono12Packed

General purpose inputs/outputs (GPIOs)

TTL I/Os	2 GPIOs (LVTTTL)
Opto-isolated I/Os	1 input, 1 output

Operating conditions/dimensions

Operating temperature	-20 °C to +60 °C (housing)
Power requirements (DC)	10.8 to 26.4 VDC AUX IEEE 802.3af, Power Class 0 PoE
Power consumption	External power: 6.2 W at 12 VDC Power over Ethernet: 6.7 W
Mass	100 g

Body dimensions (L × W × H in mm) 60 × 29 × 29

Quantum efficiency

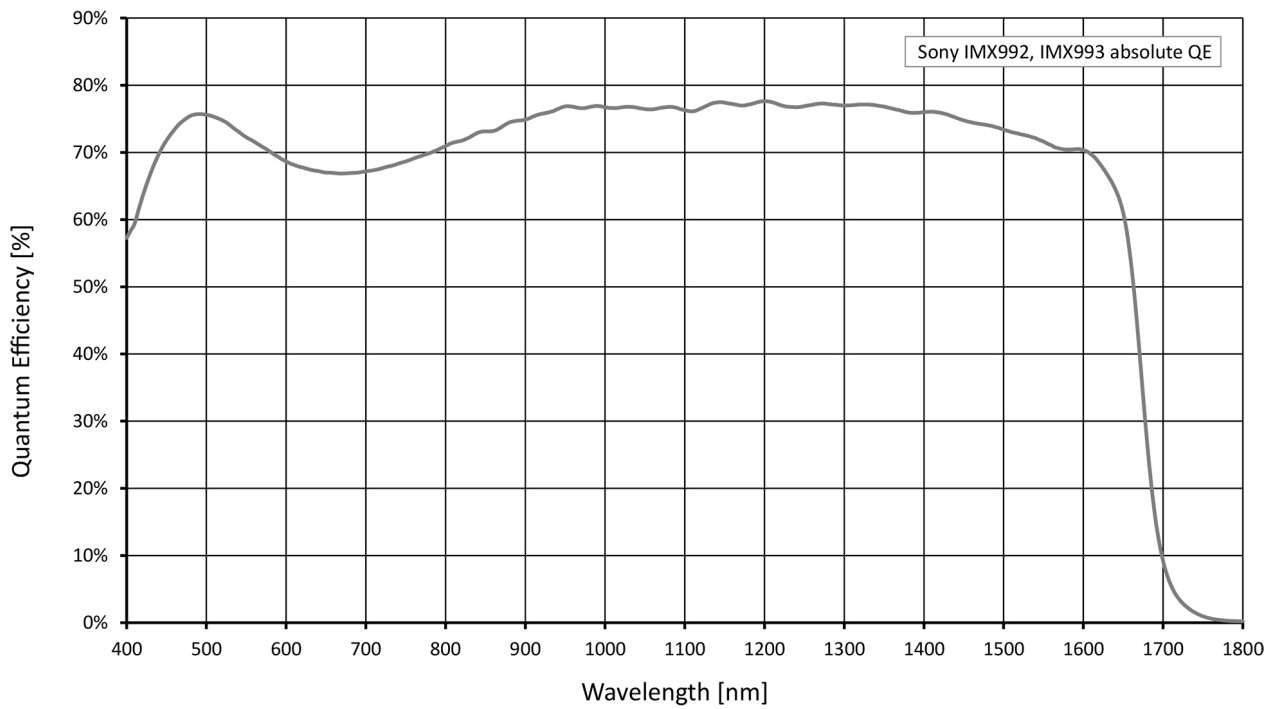

Features

Image control: Auto

- Auto exposure
- Auto gain

Image control: Other

- Adaptive noise correction
- Binning (digital)
- Black level
- Contrast
- Custom convolution
- DPC (defect pixel correction)
- Gamma
- Lens shading correction
- LUT (look-up table)
- Multiple ROIs (regions of interest)
- Reverse X/Y
- ROI (region of interest)
- Sharpness/Blur

Camera control

- Acquisition frame rate
- Action commands, incl. ToE (trigger over Ethernet)
- Bandwidth control
- Burst mode
- Counters and timers
- Event channel
- Firmware update in the field
- I/O and trigger control
- Image chunk data
- Power Saving Mode
- PTP (IEEE 1588 Precision Time Protocol)
- Readout modes (SensorBitDepth)
- Sequencer
- Serial I/Os
- Temperature monitoring
- User sets

Technical drawing

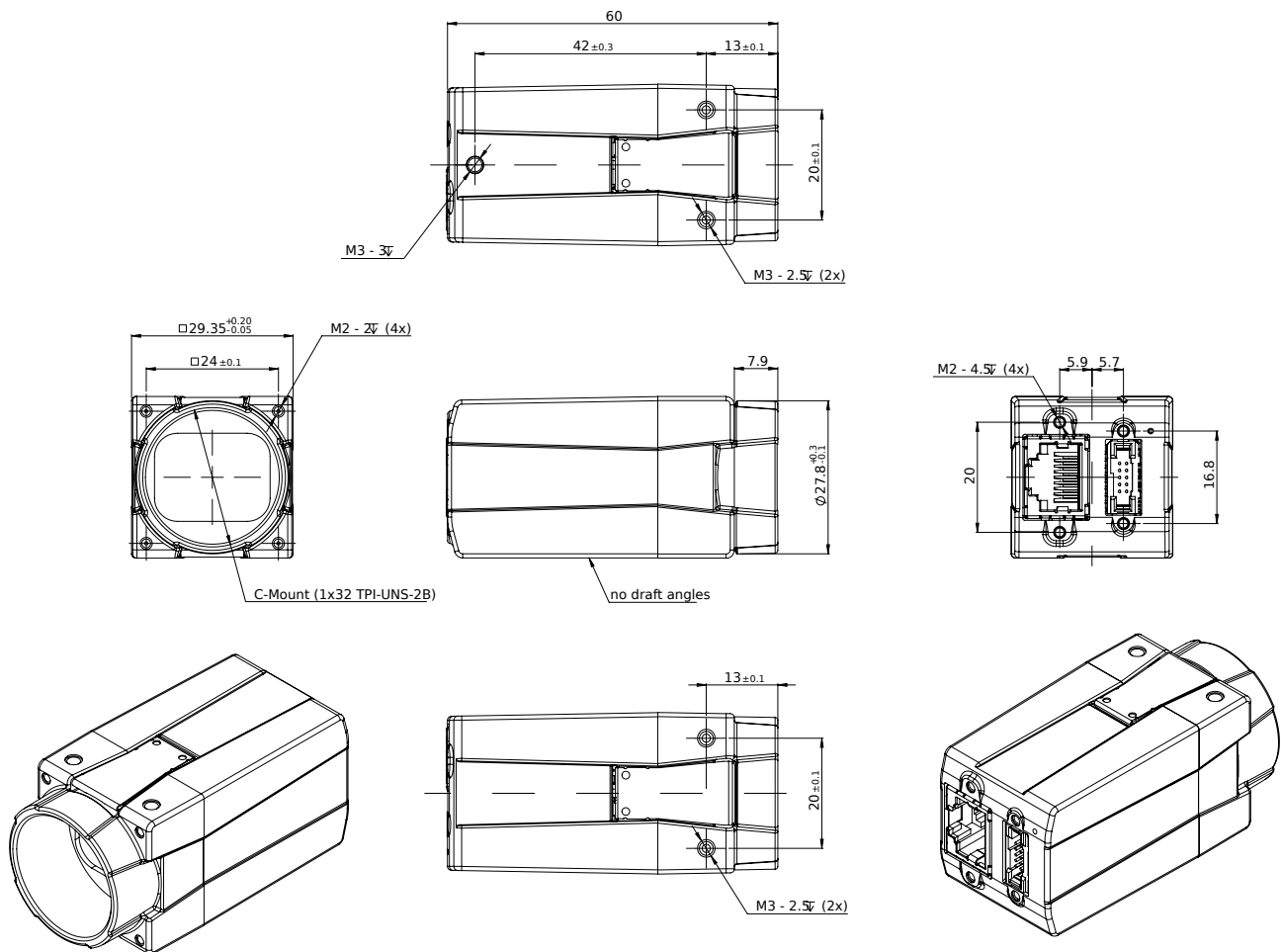

Applications

Alvium 1800 G5-530 VSWIR cameras are sensitive in the visible and the SWIR spectrum and are well-suited for many typical SWIR applications in various industry branches:

- Semiconductor industry: Solar cell and chip inspection
- Recycling industry: Plastic sorting
- Medical imaging, sciences: Hyper- and multi-spectral imaging
- Glass industry: Defect detection through hot glass
- Agriculture industry: Airborne remote sensing
- Printing industry: Seeing hidden features
- Surveillance: Vision enhancement (for example, seeing through fog or haze)
- Security: Counterfeit detection (such as for money, faked hair, or skin)