



- Ultra-compact design
- Teledyne e2v Sapphire CMOS sensor
- Switchable shutter modes
- 62 fps at full resolution

Small and powerful

## Ultra-compact GigE Vision cameras

Mako G-131 with Teledyne e2v EV76C560 runs 62.0 frames per second at 1.3 MP resolution.

Mako G is an attractively priced GigE Vision-compliant camera in a compact rugged industrial housing. Many models include advanced functionalities such as Precision Time Protocol (PTP), Trigger over Ethernet (ToE) Action Commands, and Power over Ethernet (PoE). Screw mount RJ45 connector and multiple I/Os facilitate your straightforward system integration. Mako G cameras are also available as Near Infrared (NIR) and polarizer variants.

Easy software integration with Allied Vision's [Vimba Suite](#) and compatibility to the most popular [third party image-processing libraries](#).

See the [Modular Concept](#) for lens mount, housing variants, optical filters, case design, and other modular options. See the [Customization and OEM Solutions](#) webpage for additional options.

## Specifications

Mako G-131	
Interface	IEEE 802.3 1000BASE-T, IEEE 802.3af (PoE)
Resolution	1280 (H) × 1024 (V)
Sensor	Teledyne e2v EV76C560
Sensor type	CMOS
Shutter mode	Global, Global reset, and Rolling shutter
Sensor size	Type 1/1.8

## Mako G-131

Pixel size	5.3 $\mu\text{m}$ $\times$ 5.3 $\mu\text{m}$
Lens mounts (available)	C-Mount, CS-Mount
Max. frame rate at full resolution	62 fps
ADC	10 Bit
Image buffer (RAM)	64 MByte

## Imaging performance

Imaging performance data is based on the evaluation methods in the EMVA 1288 Release 3.1 standard for characterization of image sensors and cameras. Measurements are typical values for monochrome models measured at full resolution without optical filter. Contact Sales or AE for more information.

Quantum efficiency at 529 nm	58 %
Temporal dark noise	25.7 $e^-$
Saturation capacity	9800 $e^-$
Dynamic range	51.4 dB
Absolute sensitivity threshold	26.4 $e^-$

## Output

Bit depth	8/10 Bit
Monochrome pixel formats	Mono8, Mono10
YUV color pixel formats	YUV411Packed, YUV422Packed, YUV444Packed
RGB color pixel formats	RGB8Packed, BGR8Packed
Raw pixel formats	BayerBG8, BayerBG10

## General purpose inputs/outputs (GPIOs)

Opto-isolated I/Os	1 input, 3 outputs
--------------------	--------------------

## Operating conditions/dimensions

Operating temperature	+5 $^{\circ}\text{C}$ to +45 $^{\circ}\text{C}$ housing temperature
Power requirements (DC)	10.8 to 26.4 VDC AUX or 802.3at Type 1 PoE
Power consumption	2.0 W at 12 VDC; 2.2 W PoE
Mass	80 g (with C-Mount)
Body dimensions (L $\times$ W $\times$ H in mm)	60.5 $\times$ 29.2 $\times$ 29.2 (including connectors)
Regulations	CE: 2014/30/EU (EMC), 2011/65/EU, including amendment 2015/863/EU (RoHS); FCC Class B; CAN ICES-003

## Quantum efficiency

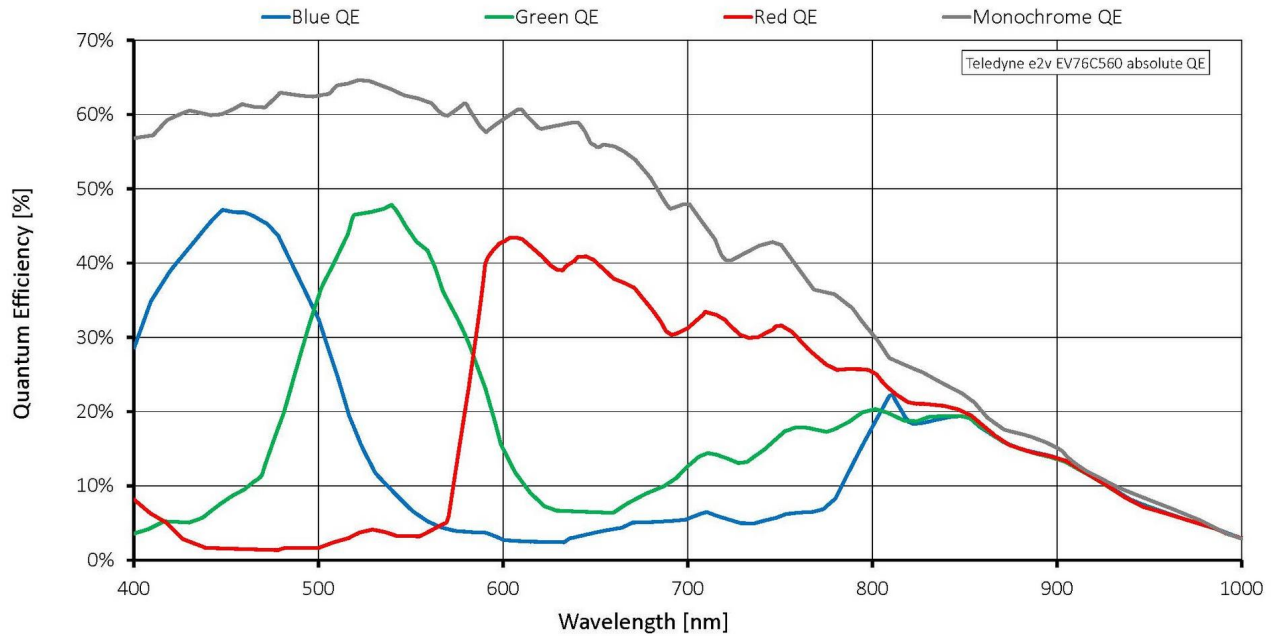

## Features

Image optimization features:

- Auto gain (manual gain control: 0 to 24 dB, 1 dB increments)
- Auto exposure (exposure time control varies by pixel format)
- Auto white balance (color models)
- Binning (1x1 and 2x2 binning)
- Color correction, hue, saturation (color models)
- Decimation
- Defect pixel masking (user defined with Defect Mask Loader tool)
- Gamma correction
- One look-up table
- Region of interest, separate region for auto features
- Reverse X/Y

## Camera control features:

- Event channel
- Image chunk data
- Storable user sets
- StreamBytesPerSecond (bandwidth control)
- Stream hold
- Sync out modes: Trigger ready, input, exposing, readout, imaging, strobe, GPO
- Switchable Rolling, Global, Global Reset shutter modes
- Temperature monitoring (main board only)

## Technical drawing

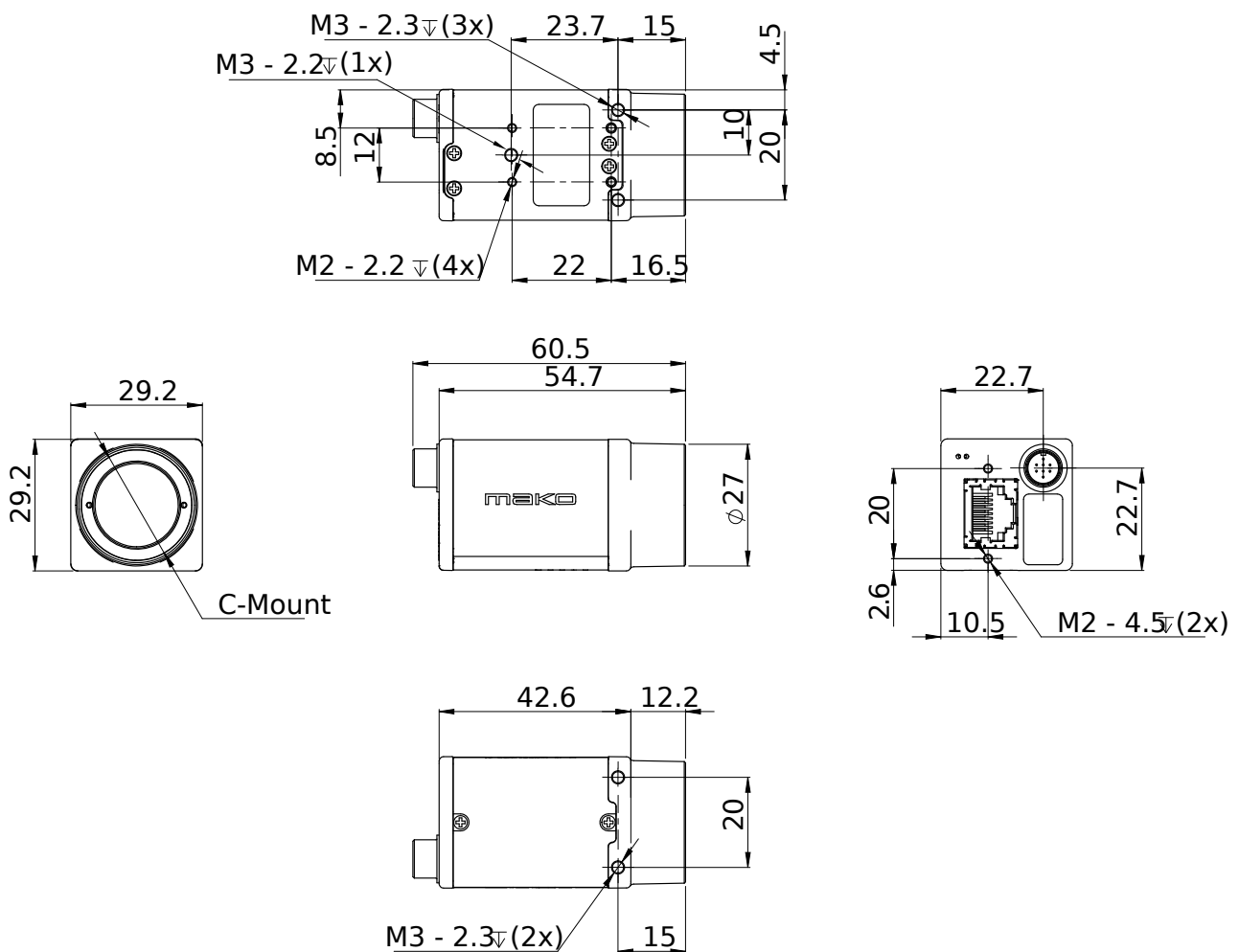



## Applications

Mako G is suitable for all typical applications in machine vision:

- Robotics
- Quality control
- Inspection, surveillance
- Industrial imaging
- Machine vision
- Logistics