



- Latest CMOS sensor
- High frame rates
- Ultra-compact
- Extensively tested accessories

Small and powerful

## Mako U - Ultra-compact USB3 Vision cameras

Mako U-130 with ON Semi PYTHON 1300 runs 168.0 frames per second at 1.3 MP resolution.

The Mako U is an attractively priced camera in a compact rugged industrial housing. It's equipped with an USB3 Vision-compliant interface technology to enable a reliable connection to your host system and image processing solution. Basic functionalities, including screw mount connectors and multiple I/Os, facilitate straightforward system integration. Mako cameras are equipped with high-quality CMOS sensors to support the realization of future-oriented applications.

Mako U monochrome USB3 Vision cameras have the same compact housing with a form factor of 49.5 x 29 x 29 mm. Screw locks ensure a safe electrical connection even in harsh industrial environments.

Every model is powered over the USB interface and has opto-isolated I/Os. The GPIOs give Mako U maximum flexibility to adapt to specific needs. The two non-isolated GPIO lines are TTL-based and programmable as input or output.

Options:

- Various IR cut/pass filters, protection glass, various lens mounts

## Specifications

<b>Mako U-130</b>	
Interface	USB3 Vision
Resolution	1280 (H) × 1024 (V)
Sensor	ON Semi PYTHON 1300

<b>Mako U-130</b>	
Sensor type	CMOS
Sensor size	Type 1/2
Pixel size	4.8 $\mu\text{m}$ $\times$ 4.8 $\mu\text{m}$
Lens mount (default)	C-Mount, CS-Mount
Max. frame rate at full resolution	168 fps
ADC	10 Bit
Image buffer (RAM)	128 MByte
<b>Imaging performance</b>	
Imaging performance data is based on the evaluation methods in the EMVA 1288 Release 3.1 standard for characterization of image sensors and cameras. Measurements are typical values for monochrome models measured at full resolution without optical filter. Contact Sales or AE for more information.	
Quantum efficiency at 529 nm	50 %
Temporal dark noise	8.2 e <sup>-</sup>
Saturation capacity	6300 e <sup>-</sup>
Dynamic range	57.1 dB
Absolute sensitivity threshold	9.0 e <sup>-</sup>
<b>Output</b>	
Bit depth	8/10 Bit
Monochrome pixel formats	Mono8, Mono10p
<b>General purpose inputs/outputs (GPIOs)</b>	
TTL I/Os	2 programmable GPIOs
Opto-isolated I/Os	1 input, 1 output
<b>Operating conditions/dimensions</b>	
Operating temperature	+5 °C to +45 °C (housing temperature)
Power requirements (DC)	Power over USB 3.0
Power consumption	2.7 W at 5 VDC
Mass	60 g
Body dimensions (L $\times$ W $\times$ H in mm)	49.5 $\times$ 29 $\times$ 29 (including connectors)
Regulations	CE: 2014/30/EU (EMC), 2011/65/EU, incl. amendment 2015/863/EU (RoHS); FCC Class B

## Quantum efficiency

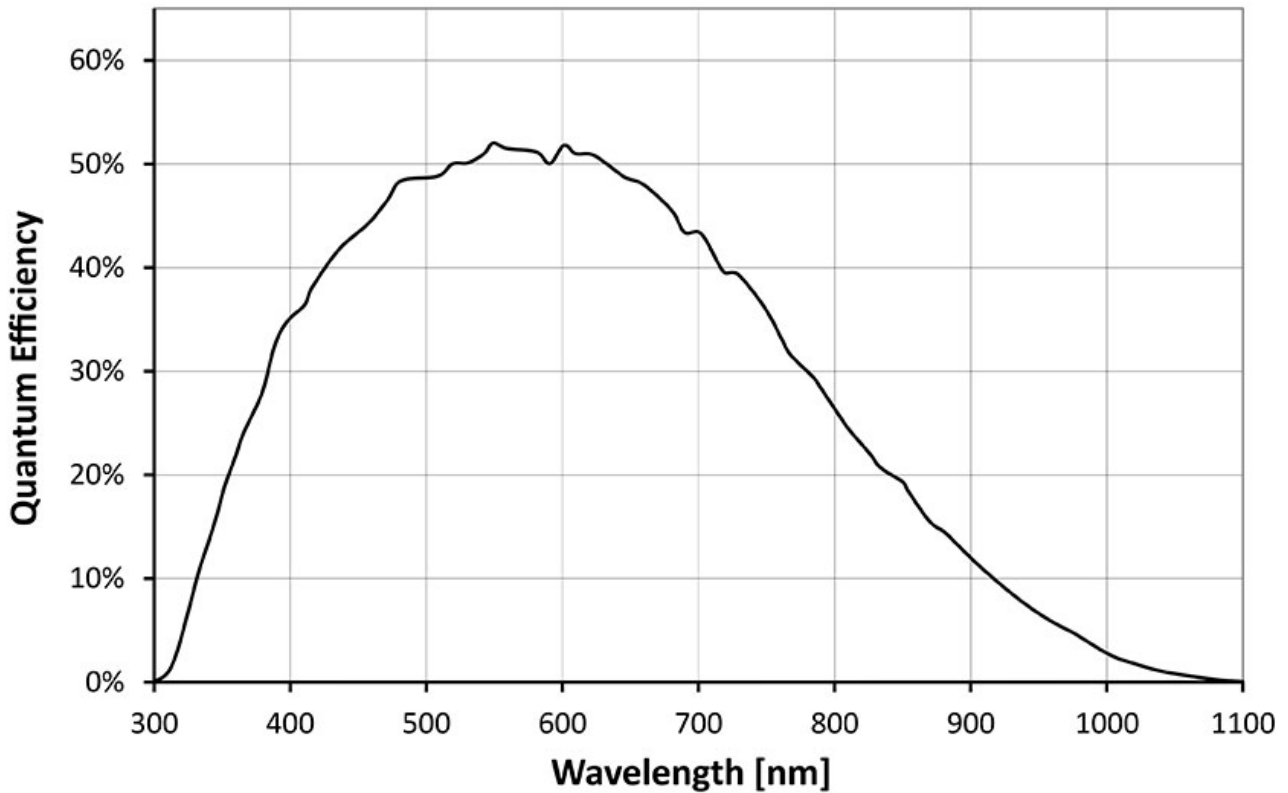

## Features

- Defect pixel correction (on/off)
- Fixed pattern noise correction (on/off)
- Region of interest (ROI)
- Gain (manual control, 0 to 20 dB)
- Exposure (manual control, 44.2  $\mu$ s to 1.4 s)
- Gamma correction
- Reverse X
- DeviceLinkThroughputLimit (easy bandwidth control)
- Sync out modes: Waiting for a trigger, exposing, readout, imaging
- Storable user sets

## Technical drawing

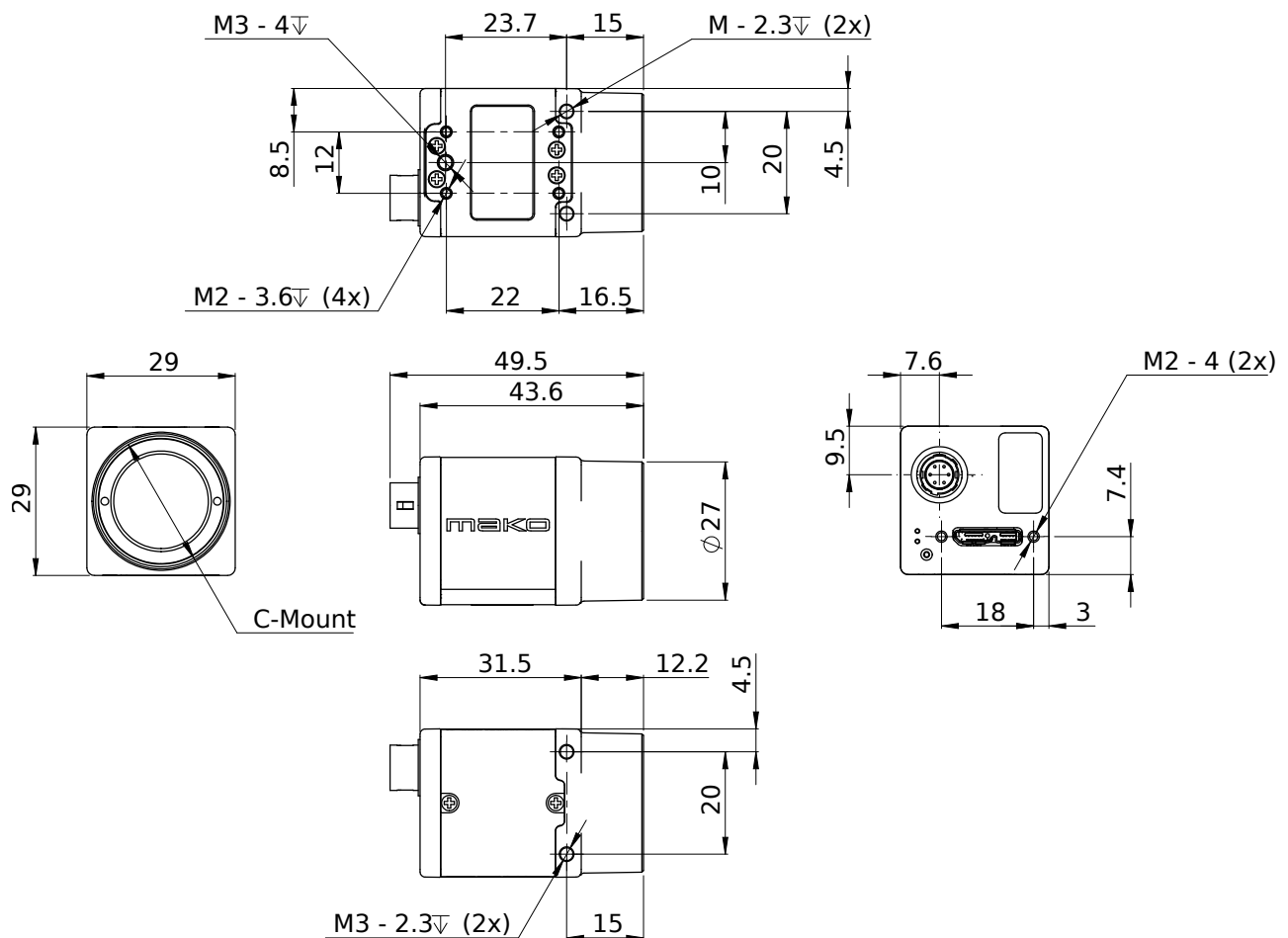

## Applications

The Mako U is an inexpensive USB 3.0 camera with a compact housing. USB 3.0 technology has lower latency and jitter times with less CPU load than other camera interfaces. Typical applications for Mako U cameras:

- Machine vision
- Quality control
- Inspection, surveillance
- Industrial imaging