



- 40 fps at full resolution
- PoE optional
- Angled-head and board level variants
- Video-iris lens control

Simplify your setup of multi-camera applications

Modular machine vision camera with GigE Vision interface

Manta G-095 with Sony ICX692 runs 40.0 frames per second at 0.9 MP resolution.

Manta is Allied Vision's most versatile GigE Vision camera series. It provides the largest choice of image sensors and its advanced feature set simplifies the setup of multi-camera applications. With its modular hardware concept, Manta offers nearly endless configuration possibilities to adapt the camera to your application.

Easy software integration with Allied Vision's [Vimba Suite](#) and compatibility to the most popular [third party image-processing libraries](#).

See the [Modular Concept](#) for lens mount, housing variants, optical filters, case design, and other modular options. See the [Customization and OEM Solutions](#) webpage for additional options.

Specifications

Interface	IEEE 802.3 1000BASE-T, IEEE 802.3af (PoE) optional
Resolution	1292 (H) × 734 (V)
Sensor	Sony ICX692
Sensor type	CCD Progressive
Shutter mode	Global shutter
Sensor size	Type 1/3
Pixel size	4.08 μm × 4.08 μm
Lens mounts (available)	C-Mount, CS-Mount
Max. frame rate at full resolution	40 fps
ADC	12 Bit
Image buffer (RAM)	32

Output

Bit depth	8/12 Bit
Monochrome pixel formats	Mono8, Mono12, Mono12Packed
YUV color pixel formats	YUV411Packed, YUV422Packed, YUV444Packed
RGB color pixel formats	RGB8Packed, BGR8Packed, RGBA8Packed, BGRA8Packed
Raw pixel formats	BayerRG8, BayerRG12Packed, BayerRG12

General purpose inputs/outputs (GPIOs)

Opto-isolated I/Os	2 inputs, 2 outputs
RS232	1

Operating conditions/dimensions

Operating temperature	+5 °C to +45 °C
Power requirements (DC)	8 to 30 VDC AUX or 802.3af PoE
Power consumption	3.6 W at 12 VDC; 4.2 W PoE
Mass	200 g; 210 g (PoE)
Body dimensions (L × W × H in mm)	86.4 × 44 × 29 (including connectors)

Quantum efficiency

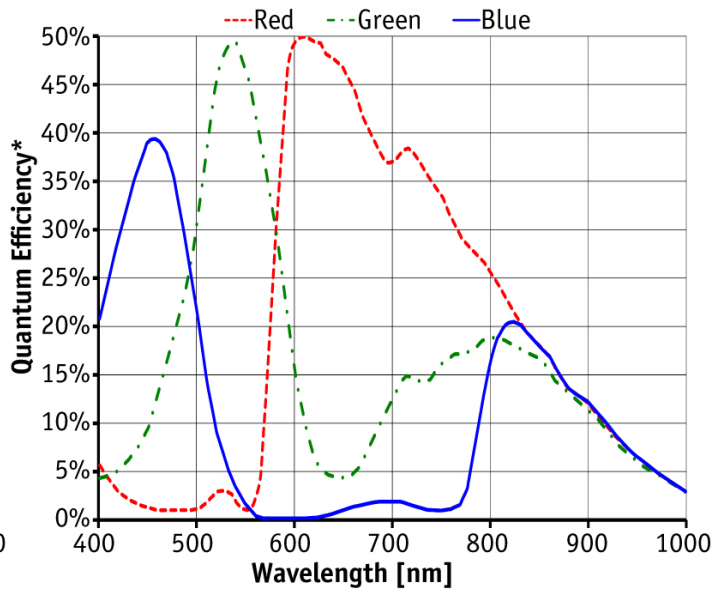
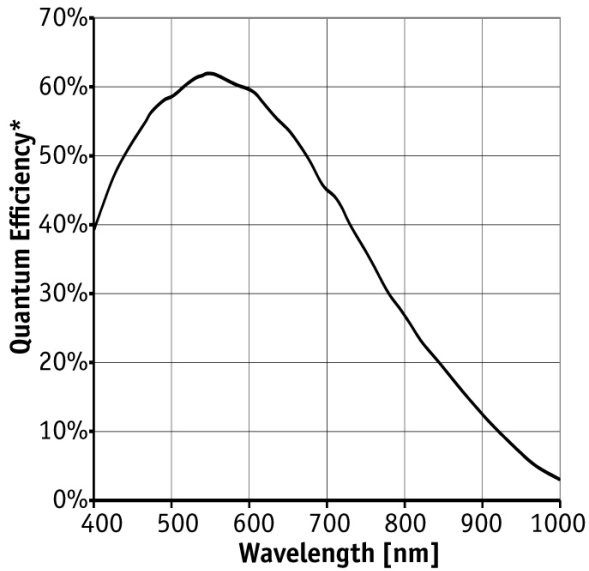

*QE measured without protection glass or filters. With glass or filters, quantum efficiency decreases by approximately 10%.

Features

- Video-type auto iris
- Region of interest, separate region for auto features
- Binning
- Decimation
- Auto gain (manual gain control: 0 to 32 dB)
- Auto exposure (45 μ s to 60 s)
- Auto white balance
- Look-up tables
- Gamma
- Hue, saturation, color correction
- StreamBytesPerSecond (easy bandwidth control)
- Stream hold
- Sync out modes: Trigger ready, input, exposing, readout, imaging, strobe, GPO
- Event channel
- Chunk data
- Storable user sets

Technical drawing

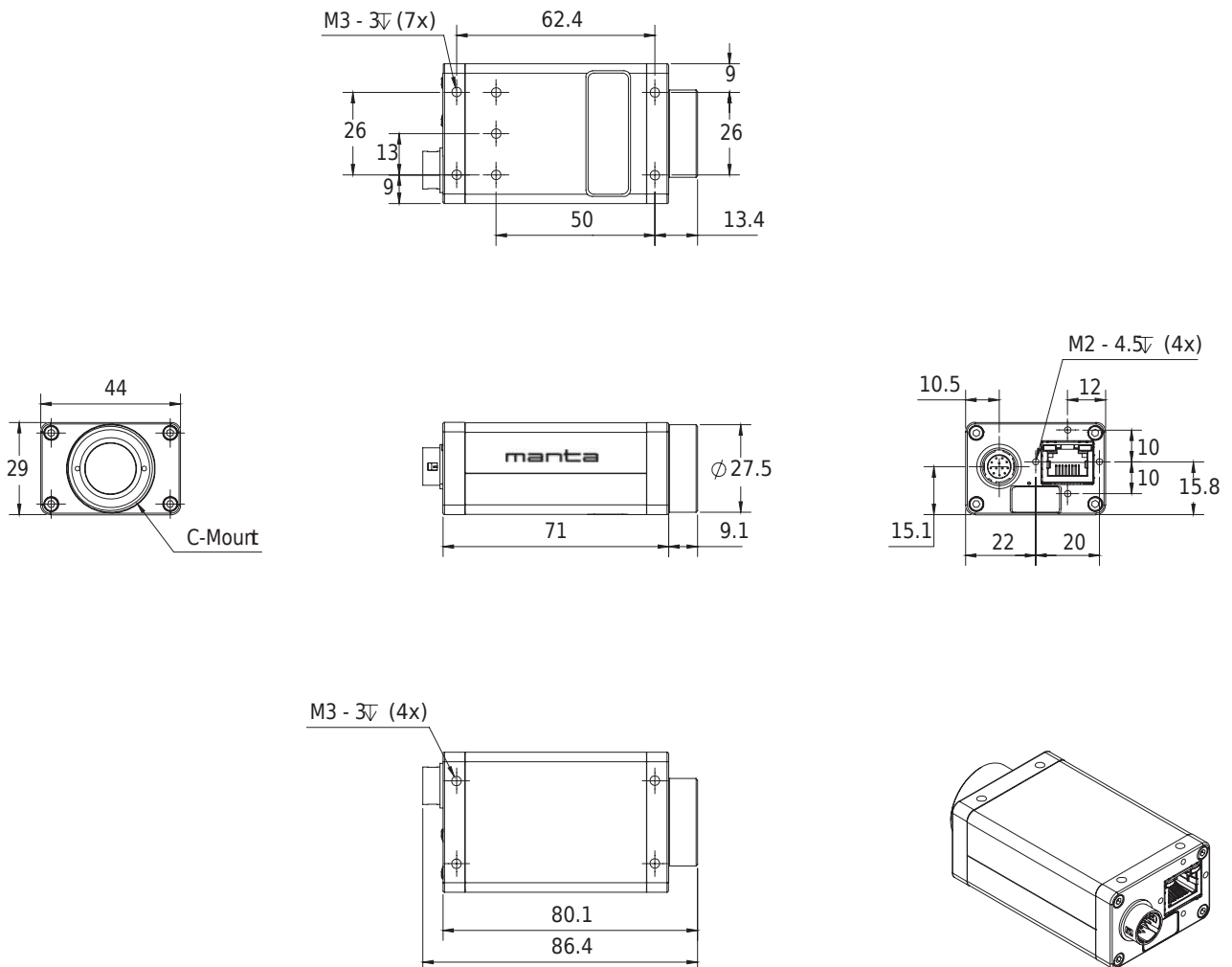

Applications

Manta G-095 is a very sensitive color camera with GigE Vision interface and PoE option. Like the other Manta cameras, it includes three separate look-up tables for R, G, and B, angled heads, or boardlevel versions with separate sensor head.

Typical applications:

- Security and Surveillance
- Imaging with low light level
- Microscopy (low light)
- ... and many more