



- IEEE 1394a camera
- Modular design
- Robust housing
- Machine vision camera

Robust housing, modular design

Compact, flexible, modular IEEE 1394a XGA C-Mount camera

Marlin F-146 with Sony ICX267 runs 17 frames per second at 1.4 MP resolution.

Acclaimed bestseller digital IEEE 1394 machine vision camera

The Marlin is Allied Vision's classical most-sold IEEE 1394 machine vision camera. Since 2004, many thousand Marlins are part of various different image processing applications. Due to its modular design (angled head, side-entry connectors, Modular Concept), it fits with almost every application.

- IEEE 1394a (400 Mb/s)
- Sony CCD sensors (1/3, 1/2, 1/1.8), 2/3 CMOS sensor
- 7 models (VGA to 2 Megapixel)
- Options
 - Various IR cut/pass filters
 - CS-Mount
 - Angled head
 - Lateral cable exit
 - White medical housing

Specifications

Interface	IEEE 1394a - 400 Mb/s, 1 port
Resolution	1392 (H) × 1040 (V)
Sensor	Sony ICX267
Sensor type	CCD Progressive
Sensor size	Type 1/2
Pixel size	4.65 μm × 4.65 μm
Lens mount (default)	C-Mount
Max. frame rate at full resolution	17 fps
ADC	12 Bit
Image buffer (RAM)	8 MByte

Output

Bit depth	8-bit to 10-bit
Monochrome pixel formats	Mono8, Mono16
RGB color pixel formats	RGB8
Raw color pixel formats (Bayer)	Raw8

General purpose inputs/outputs (GPIOs)

Opto-isolated I/Os	2 inputs, 2 outputs
RS232	1

Operating conditions/dimensions

Operating temperature	+5 °C to +45 °C
Power requirements (DC)	8 V to 36 V
Power consumption	<3 W (@ 12 VDC)
Mass	<120 g
Body dimensions (L × W × H in mm)	72 × 44 × 29 (including connectors)

Quantum efficiency

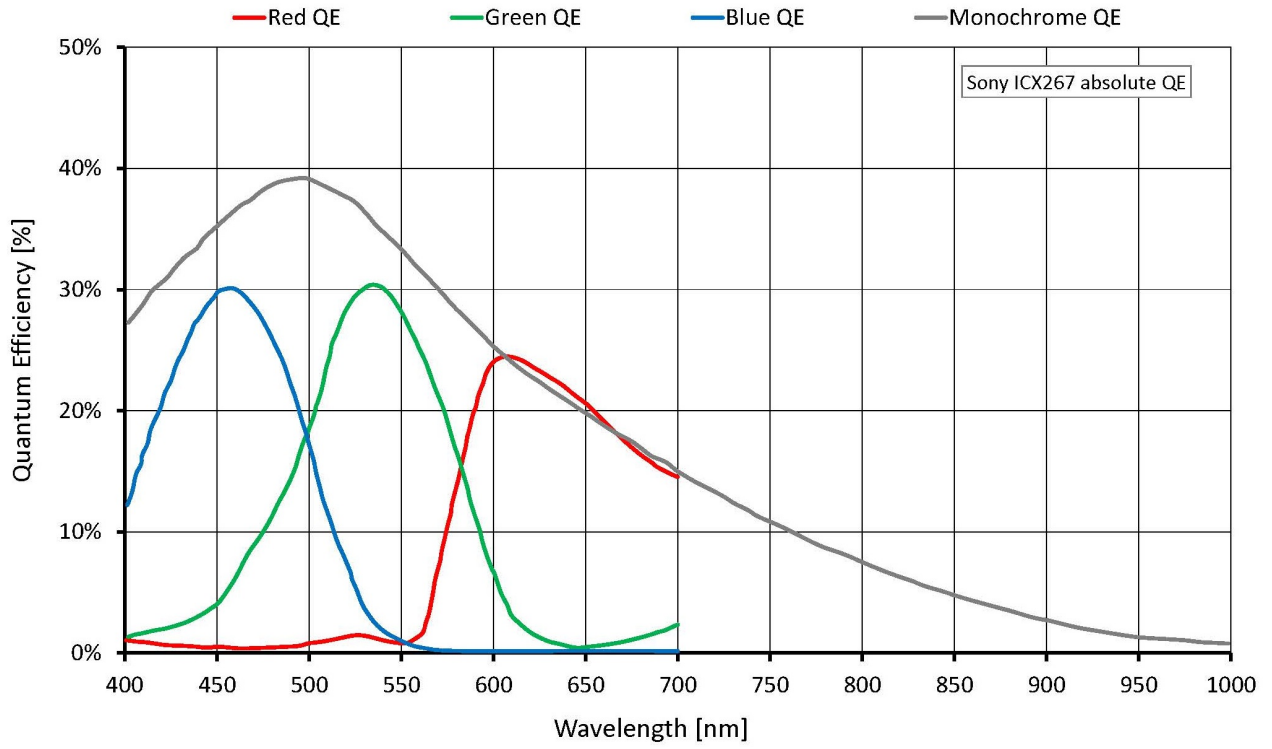

Features

Marlin cameras are equipped with many useful real-time image pre-processing functions. They are performed by the FPGA inside the camera – with no additional CPU load on the host, so that an inexpensive system is sufficient.

- Programmable look-up table (LUT), white balance, hue, saturation
- Debayering
- Auto gain, auto exposure
- Gain
 - Auto/manual
 - Manual gain control: 0 to 24 dB
- Exposure
 - Auto/manual
 - Exposure time: 46 μ s to 67 s
- Color correction
- Shading correction
- Sub-sampling, 2x binning (b/w)
- Area of interest (AOI) with speed increase
- Sequence mode - changes the image settings on the fly
- Image mirror
- Deferred image transport
- SIS (secure image signature, time stamp for trigger, frame count)
- Storable user settings

Technical drawing

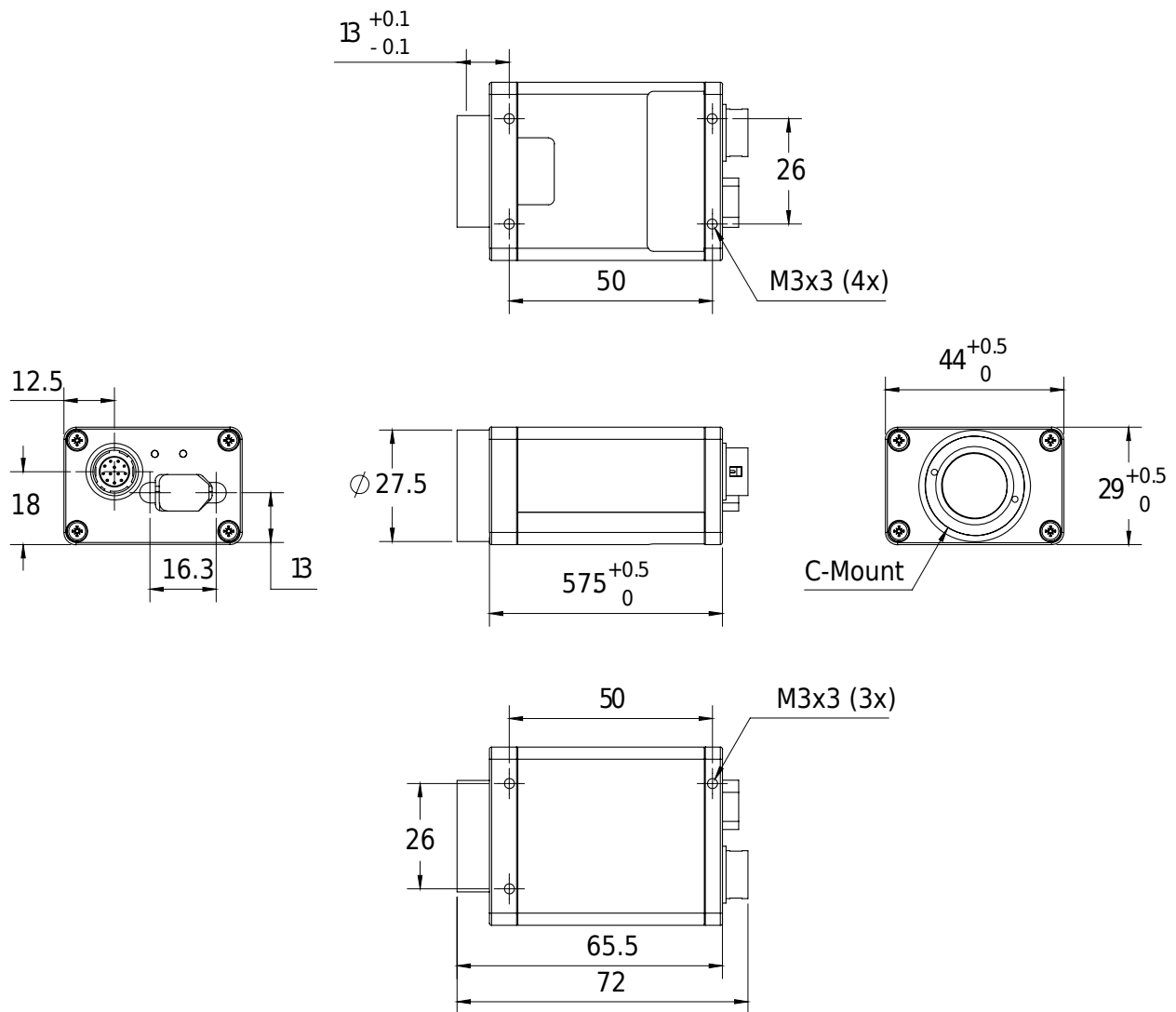

Applications

With its modular and flexible design and the real-time pre-processing functions, this Marlin camera fits for many applications:

- Machine vision
- Quality control
- Industrial inspection