

Prosilica GC 660



- Sony ICX618 sensor
- 121 fps at full resolution
- Rugged housing
- Video-type auto iris

Compact performance

Prosilica GC - Ultra-compact GigE Vision camera

Prosilica GC 660 with Sony ICX618 runs 121.0 frames per second at 0.3 MP resolution.

The Prosilica GC is a GigE camera with an ultra-compact, lightweight housing, fast frame rates, and auto-iris control. It offers a large choice of CCD and CMOS sensors up to 5 Megapixels and fits a wide range of applications.

Easy software integration with [Allied Vision's Vimba Suite](#) and compatibility to the most popular third party image-processing libraries.

See the [Modular Concept](#) for lens mount, housing variants, optical filters, case design, and other modular options. See the [Customization and OEM Solutions webpage](#) for additional options.

Specifications

Prosilica GC 660	
Interface	IEEE 802.3 1000baseT
Resolution	658 (H) × 493 (V)
Sensor	Sony ICX618
Sensor type	CCD Progressive
Shutter mode	Global shutter
Sensor size	Type 1/4
Pixel size	5.6 μm × 5.6 μm
Lens mount (default)	C-Mount
Max. frame rate at full resolution	121 fps

Prosilica GC 660	
ADC	12 Bit
Image buffer (RAM)	64 MByte
Imaging performance	
Imaging performance data is based on the evaluation methods in the EMVA 1288 Release 3.1 standard for characterization of image sensors and cameras. Measurements are typical values for monochrome models measured at full resolution without optical filter.	
Quantum efficiency at 529 nm	79 %
Temporal dark noise	16.7 e ⁻
Saturation capacity	49400 e ⁻
Dynamic range	61.0 dB
Absolute sensitivity threshold	17.3 e ⁻
Output	
Bit depth	8/12 Bit
Monochrome pixel formats	Mono8, Mono12, Mono12Packed
RGB color pixel formats	RGB8Packed, BGR8Packed
Raw pixel formats	BayerRG8, BayerRG12, BayerRG12Packed
General purpose inputs/outputs (GPIOs)	
TTL I/Os	1 input, 1 output
Opto-isolated I/Os	1 input, 1 output
RS232	1
Operating conditions/dimensions	
Operating temperature	0 °C to +50 °C ambient (without condensation)
Power requirements (DC)	5 to 25 VDC
Power consumption	3 W at 12 VDC
Mass	105 g
Body dimensions (L × W × H in mm)	59 × 46 × 33 (including connectors)
Regulations	CE: 2014/30/EU (EMC), 2011/65/EU, including amendment 2015/863/EU (RoHS); FCC Class A; CAN ICES-003

Quantum efficiency

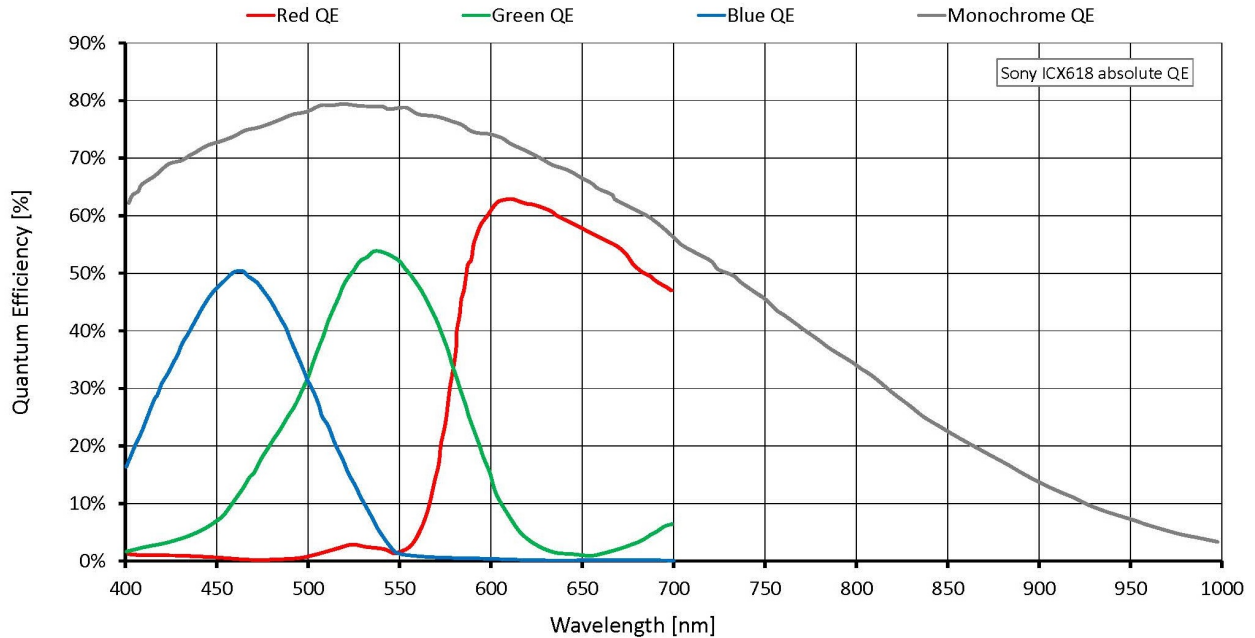

Features

Image optimization features:

- Auto gain (manual gain control: 0 to 34 dB; 1 dB increments)
- Auto exposure (manual exposure control: 10 μ s to 72.9 s; 1 μ s increments)
- Auto white balance (GC660C only)
- Binning (horizontal and vertical) (sum)
- Black level (Offset)
- Gamma correction
- Hue, saturation, color transformation (GC660C only)
- Three look-up tables
- Region of interest, DSP subregion (selectable region for auto features)

Camera control features:

- Auto-iris (video type)

- Event channel
- Global shutter (digital shutter)
- IEEE 1588 Precision Time Protocol
- Image chunk data
- Recorder and Multiframe acquisition modes
- RS232
- Three storable user sets
- StreamBytesPerSecond (bandwidth control)
- StreamHoldCapacity (up to 194 frames at full resolution)
- Sync out modes: Trigger ready, input, exposing, readout, imaging, strobe, GPO
- Temperature monitoring (mainboard only)

Technical drawing

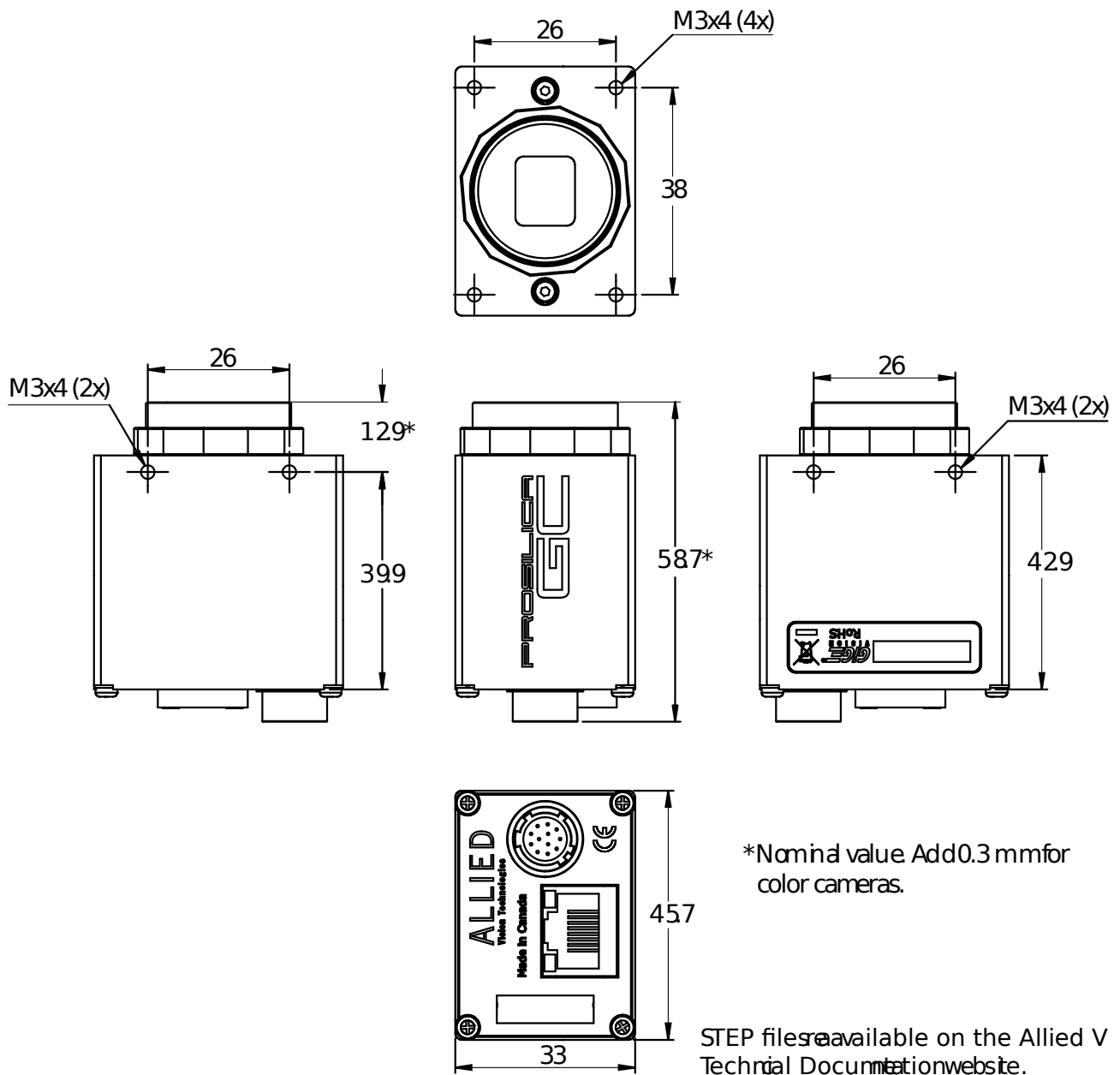

Applications

Prosilica GC660 is ideal for a wide range of applications including:

- Machine vision
- Industrial inspection
- Public security



- Traffic monitoring
- Robotics