

# Prosilica GX

## 1050C



- 240 MBps with dual port LAG technology
- 3-axis motorized lens control
- High frame rate at full bit depth
- ON Semi KAI-01050 sensor

### Shift up to double speed

The fastest Gigabit Ethernet cameras in the world -  
240MB/s

Prosilica GX 1050C with ON Semi KAI-01050 runs 112 frames per second at 1.0 MP resolution.

Prosilica GX cameras are fast, compact machine vision cameras with Gigabit Ethernet interface (GigE Vision®). The GX-Series have two screw-captivated Gigabit Ethernet ports configured as a Link Aggregation Group (LAG) to provide a sustained maximum data rate of 240 MBytes per second. Prosilica GX can also work at half the bandwidth (120 MB/s) using a single cable.

- Very Fast - 240 MB/s
- 3-axis motorized lens control and video-type autoiris
- Single or dual Ethernet port operation
- 1 to 29 Megapixel
- Fast frame rates upto 112 fps
- OnSemi KAI or Sony quad-tap CCD sensors
- Modular options available

## Specifications

Interface	IEEE 802.3 1000BASE-T
Resolution	1024 (H) × 1024 (V)
Sensor	ON Semi KAI-01050
Sensor type	CCD Progressive
Shutter mode	GS (Global shutter)
Sensor size	Type 1/2
Pixel size	5.5 μm × 5.5 μm
Lens mount (default)	C-Mount
Max. frame rate at full resolution	112 fps
ADC	14 Bit
Image buffer (RAM)	128 MByte

### Output

Bit depth	12-bit
Monochrome pixel formats	Mono8
YUV color pixel formats	YUV411Packed, YUV422Packed, YUV444Packed
RGB color pixel formats	RGB8Packed, BGR8Packed, RGBA8Packed, BGRA8Packed, RGB12Packed
Raw color pixel formats (Bayer)	BayerGR8, BayerGR12, BayerGR12Packed

### General purpose inputs/outputs (GPIOs)

Opto-isolated I/Os	2 inputs, 4 outputs
RS232	1

### Operating conditions/dimensions

Operating temperature	0 °C to +50 °C ambient (without condensation)
Power requirements (DC)	10 to 24 VDC
Power consumption	5.4 W at 12 VDC (Single GigE Mode); 6.7 W at 12 VDC (Dual GigE Mode)
Mass	269 g
Body dimensions (L × W × H in mm)	107.2 × 53.3 × 33 (including connectors)

# Quantum efficiency

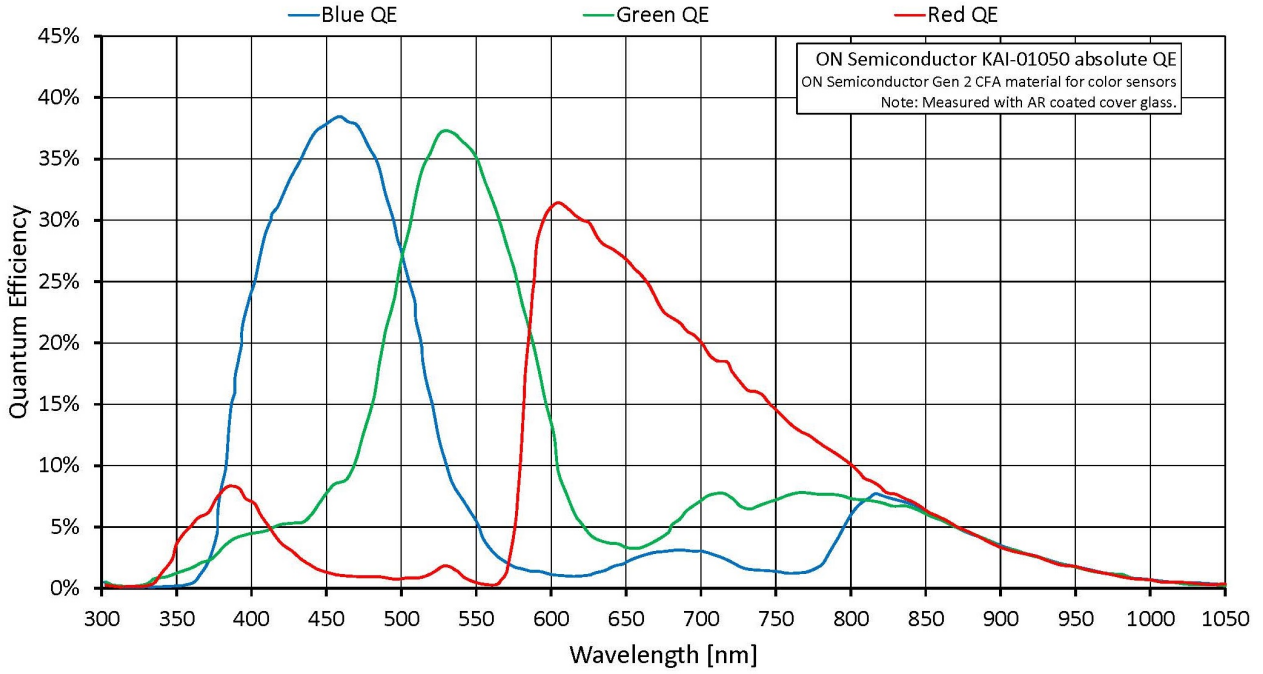

## Features

### Image optimization features:

- Auto gain (manual gain control: 0 to 34 dB)
- Auto exposure (manual exposure controls: 10  $\mu$ s to 26.8 s)
- Auto white balance
- Binning (Sum)
- Region of interest, separate region for auto features

### Camera control features:

- 3-axis motorized lens control
- Auto-Iris (video type)
- Event channel
- Global shutter (digital shutter)
- Image chunk data
- Recorder and Multiframe acquisition modes
- RS232
- Storable user sets
- StreamBytesPerSecond (bandwidth control)
- Stream hold
- Sync out modes: Trigger ready, input, exposing, readout, imaging, strobe, GPO



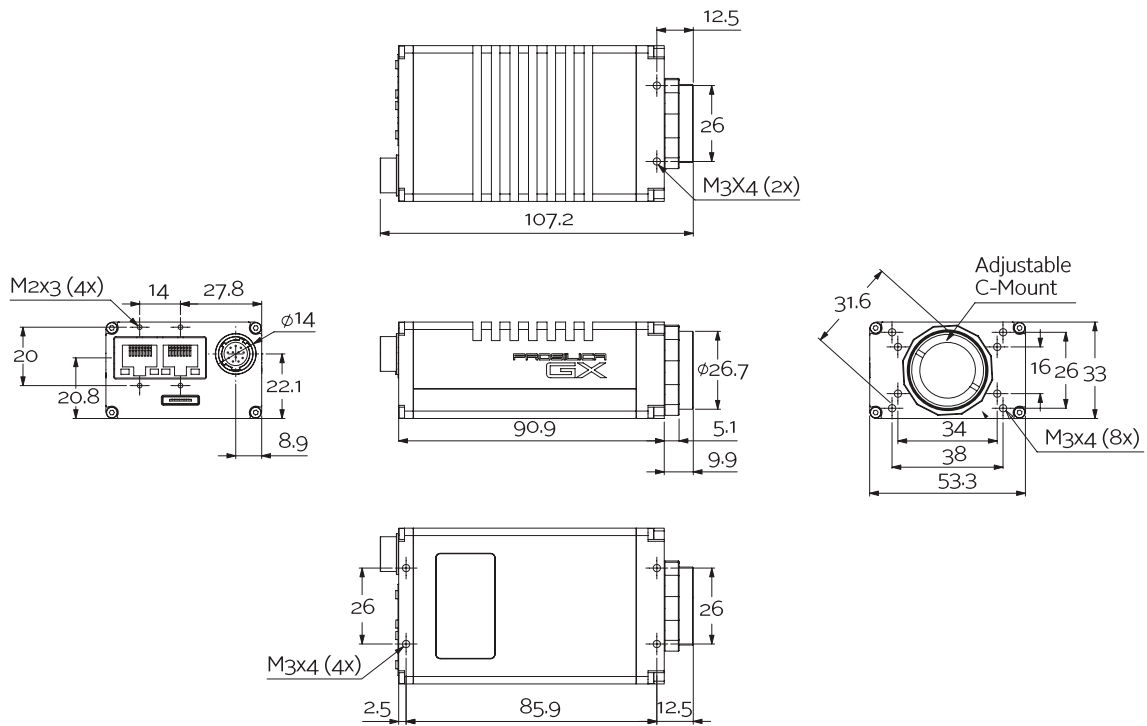

## Applications

Prosilica GX1050C is ideal for a wide range of applications including:

- Industrial inspection
- Machine vision
- Medical imaging
- Public security
- Surveillance
- Traffic imaging
- OEM applications