

# Prosilica GX 2300



- 240 MBps with dual port LAG technology
- 3-axis motorized lens control
- 32 fps at full resolution
- ON Semi KAI-04050 sensor

Shift up to double speed

The fastest Gigabit Ethernet cameras in the world - 240MB/s

Prosilica GX 2300 with ON Semi KAI-04050 runs 32.0 frames per second at 4.1 MP resolution.

Prosilica GX cameras are fast, compact machine vision cameras with Gigabit Ethernet interface (GigE Vision®). The GX-Series have two screw-captivated Gigabit Ethernet ports configured as a Link Aggregation Group (LAG) to provide a sustained maximum data rate of 240 MBytes per second. Prosilica GX can also work at half the bandwidth (120 MB/s) using a single cable.

- Very Fast - 240 MB/s
- 3-axis motorized lens control and video-type autoiris
- Single or dual Ethernet port operation
- 1 to 29 Megapixel
- Fast frame rates upto 112 fps
- OnSemi KAI or Sony quad-tap CCD sensors
- Modular options available

## Specifications

Prosilica GX 2300	
Interface	IEEE 802.3 1000baseT
Resolution	2336 (H) × 1752 (V)
Sensor	ON Semi KAI-04050
Sensor type	CCD Progressive

## Prosilica GX 2300

Shutter mode	Global shutter
Sensor size	Type 1
Pixel size	5.5 $\mu\text{m}$ $\times$ 5.5 $\mu\text{m}$
Lens mount (default)	C-Mount
Max. frame rate at full resolution	32 fps
ADC	14 Bit
Image buffer (RAM)	128 MByte
<b>Output</b>	
Bit depth	14 (monochrome); 12 (color) Bit
Monochrome pixel formats	Mono8, Mono12, Mono12Packed, Mono14
RGB color pixel formats	RGB8Packed, BGR8Packed, RGBA8Packed, BGRA8Packed, RGB12Packed
Raw pixel formats	BayerGR8, BayerGR12, BayerGR12Packed
<b>General purpose inputs/outputs (GPIOs)</b>	
Opto-isolated I/Os	2 inputs, 4 outputs
RS232	1
<b>Operating conditions/dimensions</b>	
Operating temperature	0 °C to +50 °C ambient (without condensation)
Power requirements (DC)	10 to 24 VDC
Power consumption	5.8 W at 12 VDC (Single GigE Mode); 6.9 W at 12 VDC (Dual GigE Mode)
Mass	269 g
Body dimensions (L $\times$ W $\times$ H in mm)	107.2 $\times$ 53.3 $\times$ 33 (including connectors)
Regulations	CE: 2014/30/EU (EMC), 2011/65/EU, including amendment 2015/863/EU (RoHS); FCC Class A; CAN ICES-003

## Quantum efficiency

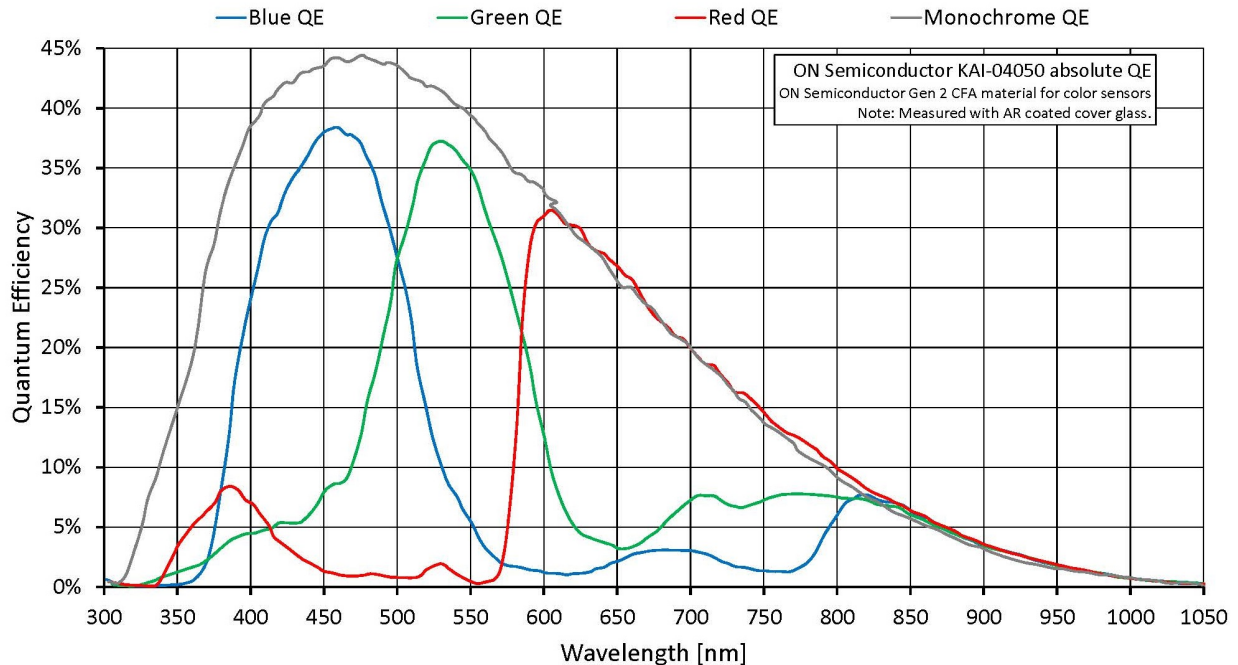

## Features

Prosilica GX2300 features include:

- 3-axis motorized lens control
- Video-type auto iris
- Region of interest (ROI), DSP subregion (selectable ROI for auto features)
- Binning (Sum)
- Auto gain (manual gain control: 0 to 34 dB)
- Auto exposure (manual exposure controls: 10  $\mu$ s to 26.8 s)
- Auto white balance
- StreamBytesPerSecond (bandwidth control)
- Stream hold
- Sync out modes: Trigger ready, input, exposing, readout, imaging, strobe, GPO
- Global shutter (digital shutter)
- Recorder and Multiframe acquisition modes



- Event channel
- Chunk data
- Storable user sets

## Technical drawing

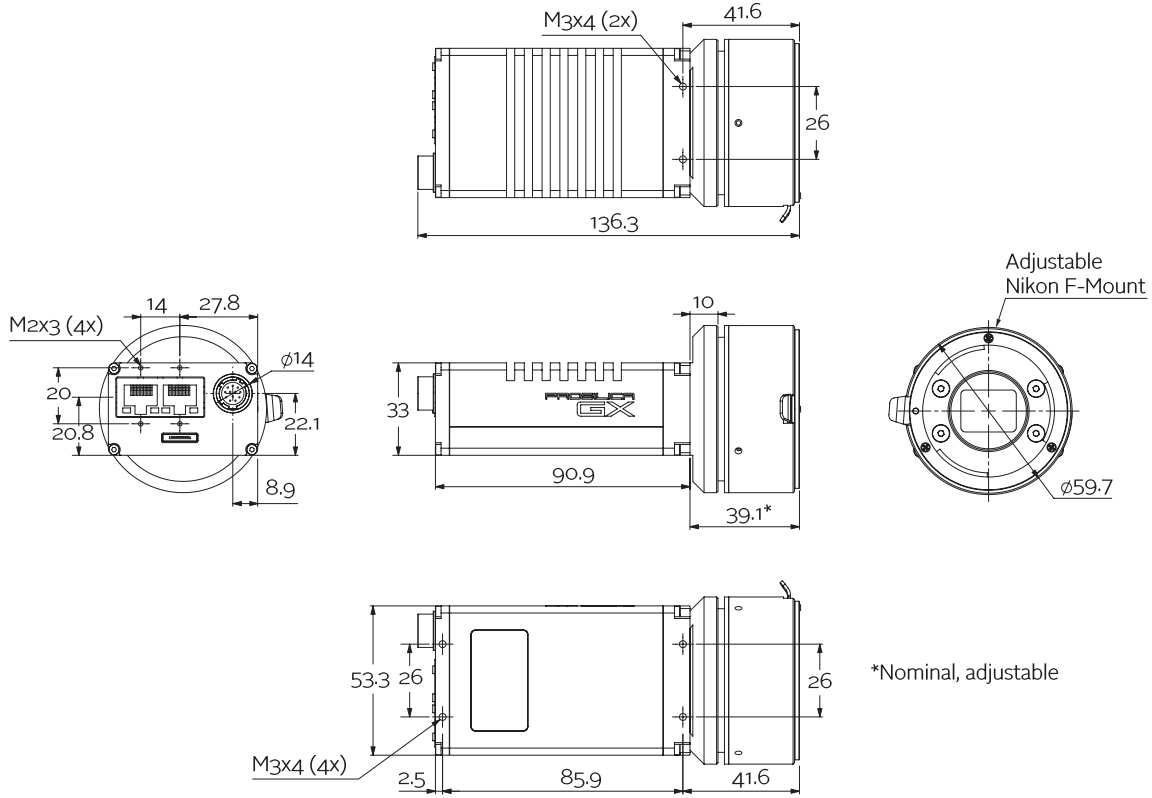

## Applications

Prosilica GX2300 is ideal for a wide range of applications including:

- LCD panel inspection
- High-resolution industrial inspection
- 3D metrology
- General machine vision
- Public security
- Military surveillance
- Traffic imaging (Intelligent Traffic Systems)
- Embedded systems
- OEM applications